



# Binks WREN® AIR BRUSHES

Models 59-10001 "A"\*\*, 59-10002 "B", and 59-10021 "C"\*\*

## OPERATING INSTRUCTIONS

\*\*Models "A" and "C" are discontinued.  
(Shown for component replacement only.)

Proficient use of the air brush is gained only after you thoroughly know the major parts of the air brush and how they operate.

### THE MECHANICAL CONTROLS

The *Trigger Button* is the square, chrome-plated button on top of the air brush. This is a single-action control in that it controls only the flow of air. Some air brushes have a double-action trigger button which controls both the flow of air and the amount of fluid being sprayed.

The small, *Knurled Screw* just below the trigger button limits the movement of the trigger button and the flow of air. This screw should be turned down (to the left) as far as it will go. Only when a spatter or stipple effect is desired should the trigger button screw be raised to the position just below the extended trigger button. Experimenting with the screw in different positions will provide a variety of lighter to heavier spatter patterns. The color droplets will increase in size as the screw is turned higher, cutting down the flow of air.

The *Air Intake* is located at the bottom of the air brush in line with the slanted trigger button. Screw the small end of the air hose to the air intake and tighten with fingers until snug.

The *Fluid Control* is located under the front end of the air brush and protrudes into the nozzle. The knurled portion of the fluid control opens or closes the flow of fluid. Turning the control clockwise opens it wider, counter-clockwise closes it.

The *Color Bottle Assembly* has a friction connection which is inserted into the opening at the bottom of the fluid control (see photo), and is fastened with a firm push-and-twist motion. Look for a small vent hole in the lid of the bottle assembly. This hole should be kept open and free of fluid because if it becomes clogged, the flow of air into the bottle is blocked, preventing the flow of color upward into the fluid control.

The *air needed* to operate the air brush can be obtained from portable or larger tank-mounted compressors. The air pressure should be about 38 psi when the air brush is not spraying; it should drop to about 30 psi when in operation. Be sure that all hose connections are tight to prevent leakage.

### USE OF THE AIR BRUSH

The colors to be sprayed, or air brushed, should be thoroughly mixed and free of lumps or pigment or other impurities. It is wise to strain the fluids through a piece of nylon stocking as you pour them into the color bottles. Your colors and paints may have to be thinned down to permit their flow through the air brush.

The air brush should be held much like a pencil, with the index finger operating the trigger button. The air hose should pass below the thumb and over the wrist to keep it out of the way.

Air brushing should be done in short strokes, or bursts. Depress and release the trigger button with each stroke. This will quickly become a habit.

Now you are ready to start. Choose a dark color to spray so you can see what is occurring. First, turn the fluid control counter-clockwise to close it. Hold the air brush about a half-inch from



the paper and depress the trigger button. Slowly open the fluid control until a wisp of color appears. It will make a small dot or, as you slowly move your hand, a small, fine line. As you open the fluid control wider, move the air brush back away from the paper and a wider line will be sprayed. Continue experimenting in this manner to learn what can be done with the air brush. The use of stencils or straight edges can quickly give varied and pleasing effects. Highlights and depth are created by air brushing some areas more lightly, or by letting the background colors show through. Stencils can be used for spraying many shapes.

### TO DISASSEMBLE THE AIR BRUSH

- Air Inlet Section (see exploded drawing, pg. 3)
  - Remove plunger (11) with special wrench, or a very small screwdriver, which releases the trigger (3) and spring (14).
  - Remove the housing (10) with special wrench, or a hex wrench. Pick out washer (13) and gasket packing (12) with straightened paper clip.
- Fluid Control or Nozzle Section (see exploded drawing, pg. 3)
  - Remove the needle portion of control with special wrench, or a hex wrench.
  - Remove nut (9) from nozzle portion with larger blade of special wrench.
  - Pick out packing (6) with straightened paper clip. (Dip in vaseline or clear lubricant when reassembling.)

### NOTE

When reassembling, dip washer and gasket in vaseline or clear lubricant, and place on top of housing and insert preassembled.

### NOTE

If air brush spits moisture, (especially in humid weather or in an air conditioned room) a moisture trap is recommended.

**Binks WREN® AIR BRUSHES – Models 59-10001 “A”, 59-10002 “B”, and 59-10021 “C”**

**TROUBLE SHOOTING**

<b>COMPLAINT</b>	<b>CAUSE</b>	<b>REMEDY</b>
<b>Air brush does not spray</b>	<p>Insufficient air supply.</p> <p>Clogged vent hole in cover of bottle.</p> <p>Clogged fluid control.</p> <p>Clogged air passage.</p> <p>Excessively heavy fluid.</p>	<p>Increase air supply—requires 28 psi to operate “A” brush, and 30 psi to operate “B” and “C” brushes.</p> <p>Carefully clean out hole with pin.</p> <p>Disassemble fluid control and soak in compatible solvent; clean out soft paint with care.</p> <p>Remove air valve plunger with a jeweler’s screwdriver, or the screwdriver end of the 59-83 wrench, before attempting to remove housing. Clean out passages with broomstraw or similar probe. Blow air through to ensure orifices are open.</p> <p>Reduce fluid viscosity with compatible solvent.</p>
<b>Air brush spits or spurts</b>	<p>Air is bypassing the packing in fluid control.</p>	<p>Remove the fluid control retainer nut and packing with the 59-83 wrench or small, wide-blade screwdriver. Replace packing, and also retainer nut, if necessary.</p>
<b>Trigger button won’t function properly</b>	<p>Trigger button spring has lost its tension.</p>	<p>Remove air valve plunger with a jeweler’s screwdriver, or the screwdriver end of the 59-83 wrench, which releases trigger button and spring. Replace spring. (Temporary repair can be made by stretching the spring).</p>

**Note:** Model 59-102 Repair Kit is available. It contains the special tool, 59-83 wrench, for complete disassembly of the air brush and an assortment of parts.

**OPERATION**

**THINNING FLUIDS**

Fluids that may be sprayed with the air brush range from light, or water-type consistency to heavy, or enamel-type consistency. It is most desirable that the fluid be of a viscosity that is sprayable, provides adequate coverage and yet will not run or sag. To achieve this, reduction, or thinning of the fluid may be necessary. When and how to correctly reduce or thin fluids is a matter of judgement and common sense.

**STRAINING FLUIDS**

Since the fluid orifices in the air brush are extremely small, it is essential that the fluid to be sprayed be free of foreign particles. It is recommended that fluids be strained through a piece of nylon stocking or similar mesh cloth before use.

**CLEANING**

Ninety-five percent of breakdowns in the operation of the Wren Air Brush are directly due to not keeping the air brush clean at all times, especially after each use. When using fast-drying fluids, such as lacquers, underglazes, etc. which will set up in five to ten minutes, it may be necessary to clean or immerse the fluid control end of the air brush in compatible solvent during intermittent use.

**Binks WREN® AIR BRUSHES – Models 59-10001 “A”\*\*, 59-10002 “B”, and 59-10021 “C”\*\***  
**\*\*Models “A” and “C” are discontinued - shown for component replacement only.**

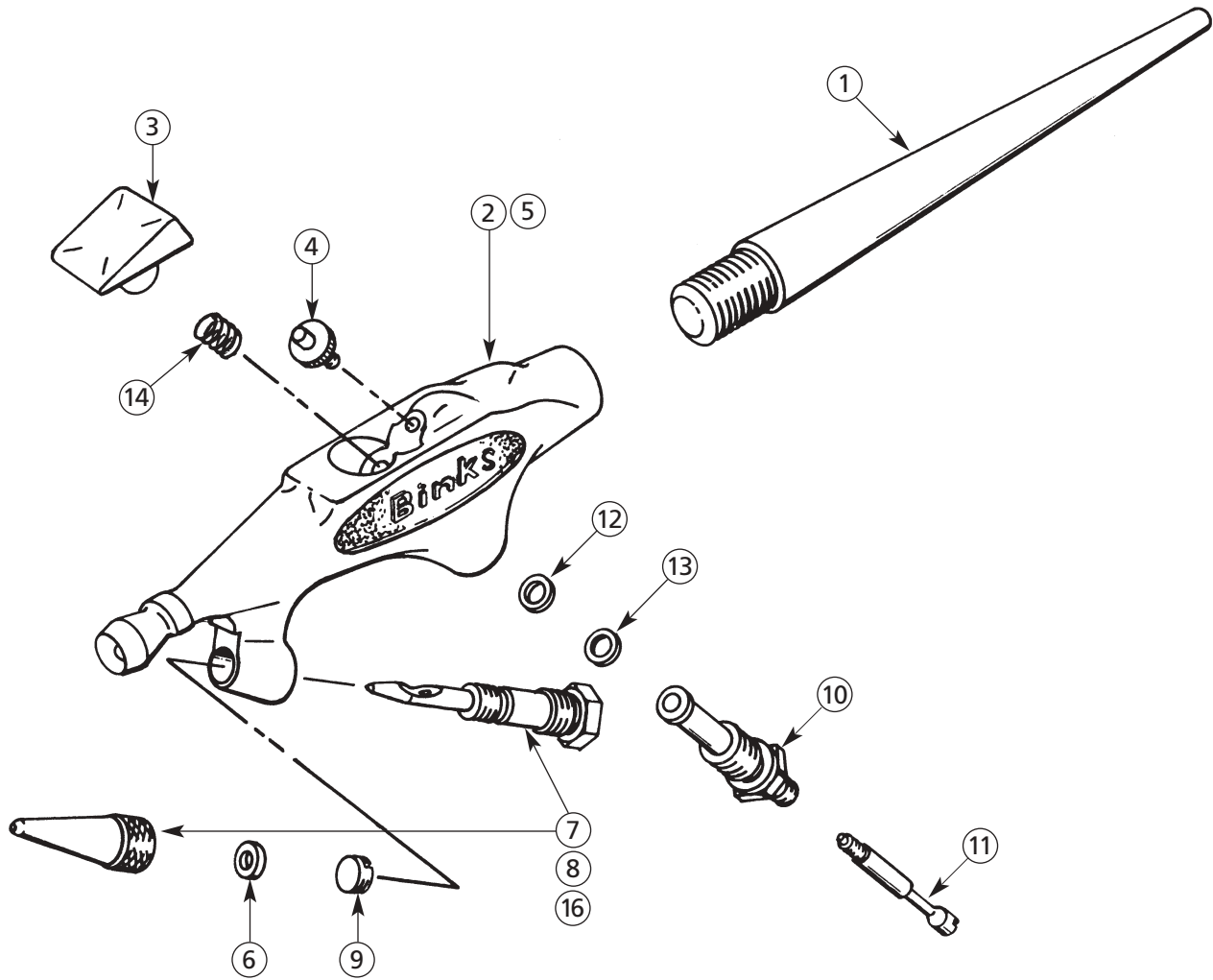

**PARTS LIST**

(When ordering, please specify Part No.)

INDEX NO.	PART NO.	DESCRIPTION	QTY.	INDEX NO.	PART NO.	DESCRIPTION	QTY.
1	■	HANDLE (5-137) .....	1	9	*■	PACKING RETAINER NUT (59-13) .....	1
2	■	BODY (WREN “B”) (59-2).....	1	10	59-20	AIR VALVE HOUSING .....	1
3	59-3	TRIGGER BUTTON .....	1	11	*●59-21	AIR VALVE PLUNGER .....	1
4	*■	AIR VALVE SCREW (59-4).....	1	12	*59-22	AIR VALVE PACKING .....	1
5	■	BODY (WREN “C”) (59-5).....	1	13	*■	AIR VALVE WASHER (59-23) .....	1
6	*59-8	FLUID CONTROL PACKING .....	1	14	*■	AIR VALVE SPRING (59-24) .....	1
7	59-9	FLUID CONTROL ASSEMBLY (WREN “A” .0292) .....	1	15	*■	WRENCH-SPECIAL (59-83) (Not Shown) ....	1
8	▲59-10	FLUID CONTROL ASSEMBLY (WREN “B” .052) .....	1	16	▲59-101	FLUID CONTROL ASSEMBLY (WREN “C” .0595) .....	1

\* Parts included in 59-102 Repair Kit.

▲ Models “B” or “C” controls are interchangeable. The “A” control can also be used on the “B” and “C” body. **Do not** use “B” or “C” Control with “A” Body.

● **Important**—Always remove No. 59-21 Plunger before removing No. 59-20 Housing.

■ Not available as individually purchased parts.

---

## STORAGE BOTTLE ASSEMBLIES

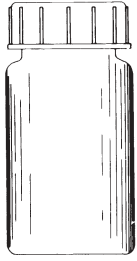

**59-78**  
Plastic 2 oz.



**59-34**  
Glass  
1/2 oz.



**59-33**  
Plastic  
1/4 oz.

---

## SIPHON BOTTLE ASSEMBLIES

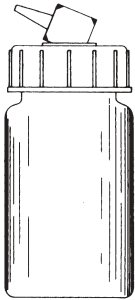

**59-81**  
Plastic  
2 oz.



**59-31**  
Glass  
1/2 oz.



**59-30**  
Plastic  
1/4 oz.

---

## HOSES

- 59-60 Vinyl Hose Assembly 6'
- 59-61 Braided Hose Assembly 6'
- 59-97 Braided Hose Assembly 10'
- 59-98 Braided Hose Assembly 12'



### 59-10006 WREN "B" SET

Includes air brush, 1/4, 1/2 and 2 fluid oz. color bottle assemblies and 59-60 (6') lightweight vinyl hose with connections, packed in an attractive, clear plastic case.

### 59-105 Regulator/Extractor

---

Sales and Service Through a Nationwide Network of Industrial Distributors.

**Customer Service in USA / 1-800-992-4657**  
**Technical Support in USA / 1-888-992-4657**



195 Internationale Blvd.  
Glendale Heights, IL 60139

1541R-12 Revisions: (P1) Revised photograph; (P4) Added 59-60 to Hoses, deleted reference to 34-3010.

Part Sheet 1541R-13 Printed in USA 11/01, All Rights Reserved